

**Latchable Single 8-Ch/Differential 4-Ch Analog Multiplexers**

**Features**

- Low  $r_{DS(on)}$ : 270  $\Omega$
- 44-V Power Supply Rating
- On-Board Address Latches
- Break-Before-Make
- Low Leakage— $I_{D(on)}$ : 30 pA

**Benefits**

- Improved System Accuracy
- Microprocessor Bus Compatible
- Easily Interfaced
- Reduced Crosstalk

**Applications**

- Data Acquisition Systems
- Automatic Test Equipment
- Avionics and Military Systems
- Medical Instrumentation

**Description**

The DG528 is an 8-channel single-ended analog multiplexer designed to connect one of eight inputs to a common output as determined by a 3-bit binary address ( $A_0, A_1, A_2$ ). DG529, a 4-channel dual analog multiplexer, is designed to connect one of four differential inputs to a common differential output as determined by its 2-bit binary address ( $A_0, A_1$ ) logic.

based applications. Break-before-make switching action protects against momentary shorting of the input signals. The DG528/529 are built on the improved PLUS-40 CMOS process. A buried layer prevents latchup.

These analog multiplexers have on-chip address and control latches to simplify design in microprocessor

The on chip TTL-compatible address latches simplify digital interface design and reduce board space in data acquisition systems, process controls, avionics, and ATE.

**Functional Block Diagrams and Pin Configurations**

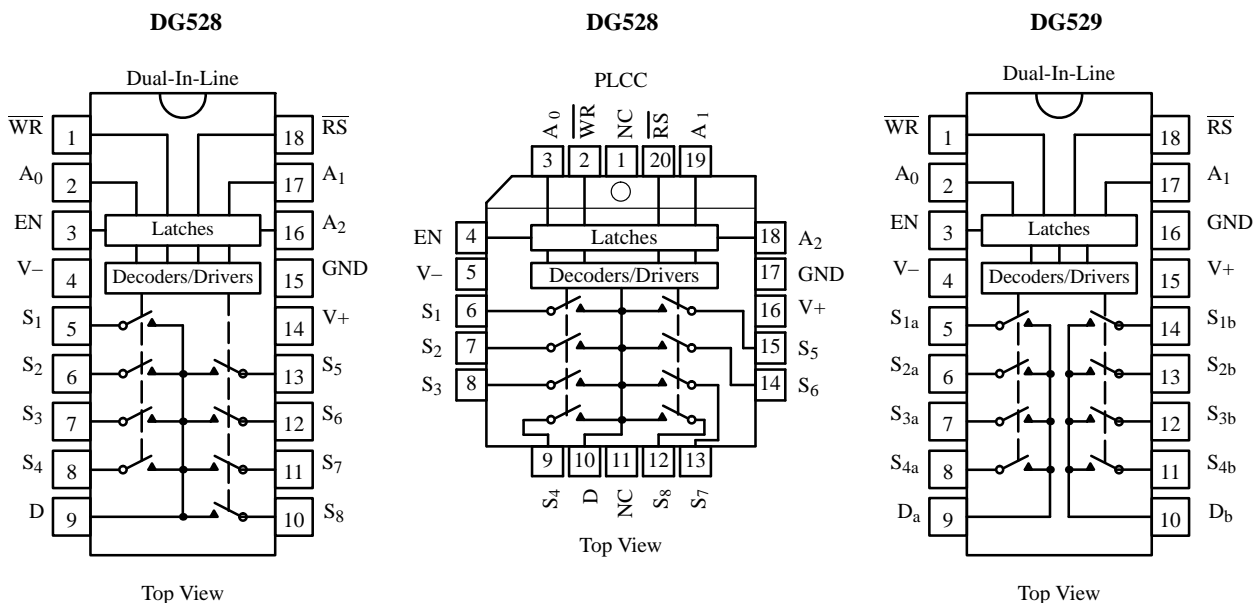

Updates to this data sheet may be obtained via facsimile by calling Siliconix FaxBack, 1-408-970-5600. Please request FaxBack document #70068.

## Truth Tables and Ordering Information

**Truth Table — DG528**  
8-Channel Single-Ended Multiplexer

A <sub>2</sub>	A <sub>1</sub>	A <sub>0</sub>	EN	$\overline{WR}$	$\overline{RS}$	On Switch
<b>Latching</b>						
X	X	X	X	$\overline{\downarrow}$	1	Maintains previous switch condition
<b>Reset</b>						
X	X	X	X	X	0	None (latches cleared)
<b>Transparent Operation</b>						
X	X	X	0	0	1	None
0	0	0	1	0	1	1
0	0	1	1	0	1	2
0	1	0	1	0	1	3
0	1	1	1	0	1	4
1	0	0	1	0	1	5
1	0	1	1	0	1	6
1	1	0	1	0	1	7
1	1	1	1	0	1	8

**Truth Table — DG529**  
Differential 4-Channel Multiplexer

A <sub>1</sub>	A <sub>0</sub>	EN	$\overline{WR}$	$\overline{RS}$	On Switch
<b>Latching</b>					
X	X	X	$\overline{\downarrow}$	1	Maintains previous switch condition
<b>Reset</b>					
X	X	X	X	0	None (latches cleared)
<b>Transparent Operation</b>					
X	X	0	0	1	None
0	0	1	0	1	1
0	1	1	0	1	2
1	0	1	0	1	3
1	1	1	0	1	4

Logic "0" = V<sub>AL</sub> ≤ 0.8 V  
 Logic "1" = V<sub>AH</sub> ≥ 2.4 V  
 X = Don't Care

**Ordering Information — DG528**

Temp Range	Package	Part Number
0 to 70°C	18-Pin Plastic DIP	DG528CJ
	20-Pin PLCC	DG528DN
-25 to 85°C	18-Pin CerDIP	DG528BK
-55 to 125°C		DG528AK
		DG528AK/883
		5962-8768901VA

**Ordering Information — DG529**

Temp Range	Package	Part Number
0 to 70°C	18-Pin Plastic DIP	DG529CJ
-25 to 85°C	18-Pin CerDIP	DG529BK
-55 to 125°C		DG529AK/883

## Absolute Maximum Ratings

Voltage Referenced to V-

V+	44 V
GND	25 V
Digital Inputs <sup>a</sup> , V <sub>S</sub> , V <sub>D</sub>	(V-) -2 V to (V+) +2 V or 30 mA, whichever occurs first
Current (Any Terminal Except S or D)	30 mA
Continuous Current, S or D	20 mA
Peak Current, S or D (Pulsed at 1 ms, 10% Duty Cycle Max)	40 mA
Storage Temperature (AK, BK Suffix)	-65 to 150°C
(CJ, DN Suffix)	-65 to 125°C

Power Dissipation (Package)<sup>b</sup>

18-Pin Plastic DIP <sup>c</sup>	470 mW
18-Pin CerDIP <sup>d</sup>	900 mW
20-Pin PLCC <sup>e</sup>	800 mW

Notes:

- Signals on S<sub>X</sub>, D<sub>X</sub> or I<sub>NX</sub> exceeding V+ or V- will be clamped by internal diodes. Limit forward diode current to maximum current ratings.
- All leads soldered or welded to PC board.
- Derate 6.3 mW/°C above 75°C.
- Derate 1.2 mW/°C above 75°C.
- Derate 10 mW/°C above 75°C.

## Specifications<sup>a</sup>

Parameter	Symbol	Test Conditions Unless Otherwise Specified $V_+ = 15\text{ V}$ , $V_- = -15\text{ V}$ , $WR = 0$ $RS = 2.4\text{ V}$ , $V_{IN} = 2.4\text{ V}$ , $0.8\text{ }\mu\text{F}^f$		Temp <sup>b</sup>	Typ <sup>c</sup>	A Suffix -55 to 125°C		B, C, D Suffix -40 to 85°C		Unit
						Min <sup>d</sup>	Max <sup>d</sup>	Min <sup>d</sup>	Max <sup>d</sup>	
<b>Analog Switch</b>										
Analog Signal Range <sup>e</sup>	$V_{ANALOG}$		Full			-15	15	-15	15	V
Drain-Source On-Resistance	$r_{DS(on)}$	$V_D = \pm 10\text{ V}$ , $I_S = -200\text{ }\mu\text{A}$	Room Full	270			400 500		450 550	$\Omega$
Greatest Change in $r_{DS(on)}$ Between Channels <sup>f</sup>	$\Delta r_{DS(on)}$	$-10\text{ V} < V_S < 10\text{ V}$	Room	6						%
Source Off Leakage Current	$I_{S(off)}$	$V_{EN} = 0\text{ V}$ , $V_S = \pm 10\text{ V}$ $V_D = \mp 10\text{ V}$	Room Full	$\pm 0.005$		-1 -50	1 50	-5 -50	5 50	nA
Drain Off Leakage Current	$I_{D(off)}$	$V_{EN} = 0\text{ V}$ $V_D = \pm 10\text{ V}$ $V_S = \mp 10\text{ V}$	DG528	Room Full	$\pm 0.015$	-10 -200	10 200	-20 -200	20 200	
			DG529	Room Full	$\pm 0.008$	-10 -100	10 100	-20 -100	20 100	
Drain On Leakage Current	$I_{D(on)}$	$V_S = V_D = \pm 10\text{ V}$ $V_{EN} = 2.4\text{ V}$	DG528	Room Full	$\pm 0.03$	-10 -200	10 200	-20 -200	20 200	
			DG529	Room Full	$\pm 0.015$	-10 -100	10 100	-20 -100	20 100	
<b>Digital Control</b>										
Logic Input Current	$I_{AH}$	$V_A = 2.4\text{ V}$	Room Hot	-0.002		-10 -30		-10 -30		$\mu\text{A}$
Input Voltage High		$V_A = 15\text{ V}$	Room Hot	0.006			10 30		10 30	
Logic Input Current Input Voltage Low	$I_{AL}$	$V_{EN} = 0\text{ V}$ , $2.4\text{ V}$ , $V_A = 0\text{ V}$ $RS = 0\text{ V}$ , $WR = 0\text{ V}$	Room Hot	-0.002		-10 -30		-10 -30		
<b>Dynamic Characteristics</b>										
Transition Time	$t_{TRANS}$	See Figure 5	Room	0.6			1			$\mu\text{s}$
Break-Before-Make Interval	$t_{OPEN}$	See Figure 4	Room	0.2						
EN and WR Turn-On Time	$t_{ON(EN, WR)}$	See Figures 6 and 7	Room	1			1.5			
EN and WR Turn-Off Time	$t_{OFF(EN, WR)}$	See Figures 6 and 8	Room	0.4			1			
Charge Injection	Q	$V_S = 0\text{ V}$ , $R_y = 0\text{ }\Omega$ $C_L = 10\text{ }\mu\text{F}$	Room	4						pC
Off Isolation	OIRR	$V_{EN} = 0\text{ V}$ , $R_L = 1\text{ k}\Omega$ $C_L = 15\text{ pF}$ $V_S = 7\text{ V}_{RMS}$ , $f = 500\text{ kHz}$	Room	68						dB
Logic Input Capacitance	$C_{in}$	$f = 1\text{ MHz}$	Room	2.5						pF
Source Off Capacitance	$C_{S(off)}$	$V_{EN} = 0\text{ V}$ , $V_S = 0\text{ V}$ $f = 140\text{ kHz}$	Room	5						
Drain Off Capacitance	$C_{D(off)}$	$V_{EN} = 0\text{ V}$ $V_D = 0\text{ V}$ $f = 140\text{ kHz}$	DG528	Room	25					
			DG529	Room	12					
<b>Minimum Input Timing Requirements</b>										
Write Pulse Width	$t_W$		Full			300		300		ns
$A_X$ , EN Setup Time	$t_S$		Full			180		180		
$A_X$ , EN Hold Time	$t_H$		Full			30		30		
Reset Pulse Width	$t_{RS}$	$V_S = 5\text{ V}$ , See Figure 3	Full			500		500		

## Specifications<sup>a</sup>

Parameter	Symbol	Test Conditions Unless Otherwise Specified $V_+ = 15\text{ V}$ , $V_- = -15\text{ V}$ , $WR = 0$ $RS = 2.4\text{ V}$ , $V_{IN} = 2.4\text{ V}$ , $0.8\text{ }\mu\text{F}^f$	Temp <sup>b</sup>	Typ <sup>c</sup>	A Suffix -55 to 125°C		B, C, D Suffix -40 to 85°C		Unit
					Min <sup>d</sup>	Max <sup>d</sup>	Min <sup>d</sup>	Max <sup>d</sup>	
<b>Power Supplies</b>									
Positive Supply Current	I+	$V_{EN} = 0\text{ V}$ , $V_A = 0$	Room			2.5		2.5	mA
Negative Supply Current	I-		Room		-1.5		-1.5		

Notes:

- Refer to PROCESS OPTION FLOWCHART.
- Room = 25°C, Full = as determined by the operating temperature suffix.
- Typical values are for DESIGN AID ONLY, not guaranteed nor subject to production testing.
- The algebraic convention whereby the most negative value is a minimum and the most positive a maximum, is used in this data sheet.
- Guaranteed by design, not subject to production test.
- $V_{IN}$  = input voltage to perform proper function.

## Typical Characteristics

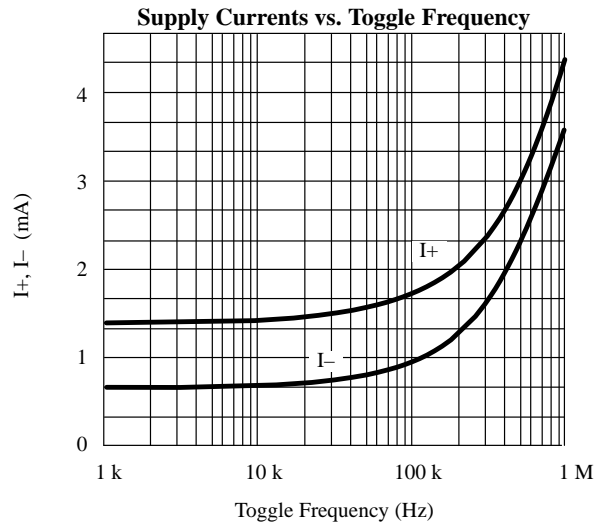
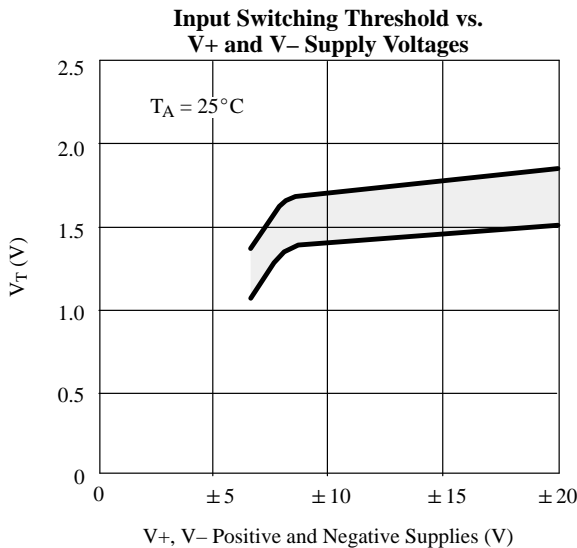
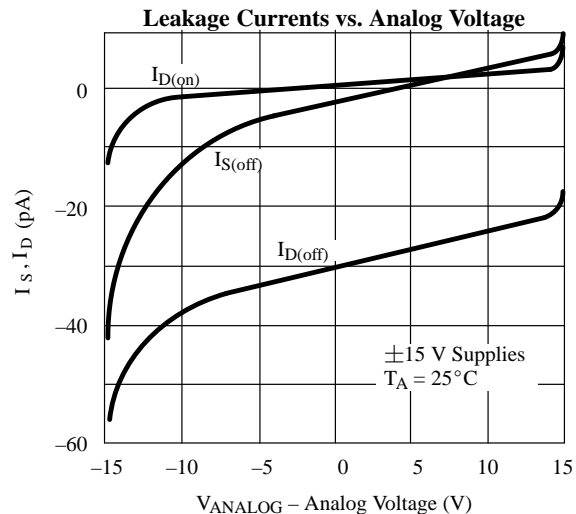
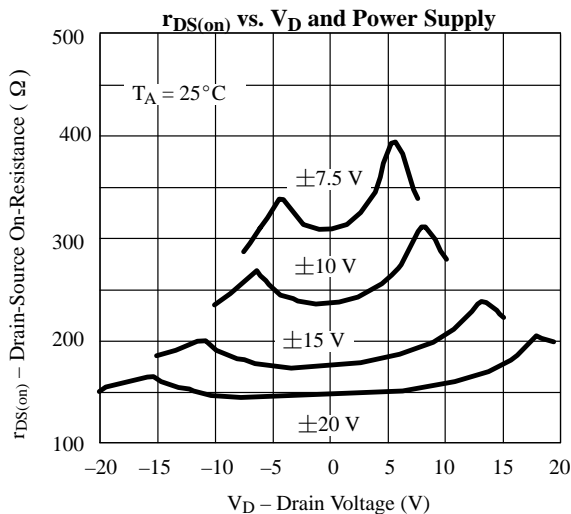

**Schematic Diagram**

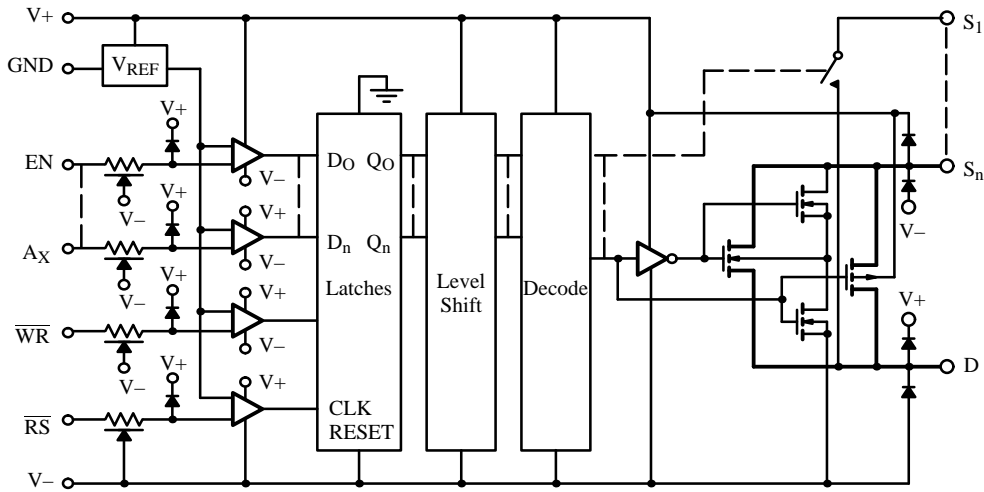

**Figure 1.**

**Detailed Description**

The internal structure of the DG528/DG529 includes a 5-V logic interface with input protection circuitry followed by a latch, level shifter, decoder and finally the switch constructed with parallel n- and p-channel MOSFETs (see Figure 1).

The logic interface circuit compares the TTL input signal against a TTL threshold reference voltage. The output of the comparator feeds the data input of a D type latch. The level sensitive D latch continuously places the  $D_X$  input signal on the  $Q_X$  output when the  $\overline{WR}$  input is low, resulting in transparent latch operation. As soon as  $\overline{WR}$  returns high, the latches hold the data last present on the  $D_X$  input, subject to the minimum input timing requirements.

Following the latches the  $Q_X$  signals are level shifted and decoded to provide proper drive levels for the CMOS switches. This level shifting insures full on/off switch operation for any analog signal present between the  $V+$  and  $V-$  supply rails.

The EN pin is used to enable the address latches during the  $\overline{WR}$  pulse. It can be hard-wired to the logic supply or to  $V+$  if one of the channels will always be used (except during a reset) or it can be tied to address decoding circuitry for memory mapped operation. The  $\overline{RS}$  pin is used as a master reset. All latches are cleared regardless of the state of any other latch or control line. The  $\overline{WR}$  pin is used to transfer the state of the address control lines to their latches, except during a reset or when EN is low (see Truth Tables).

**Timing Diagrams**

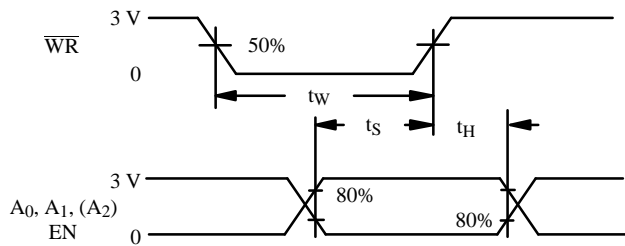

**Figure 2.**

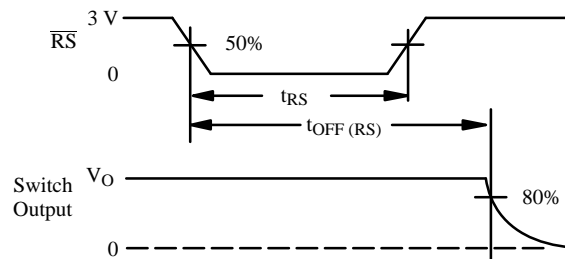

**Figure 3.**

## Test Circuits

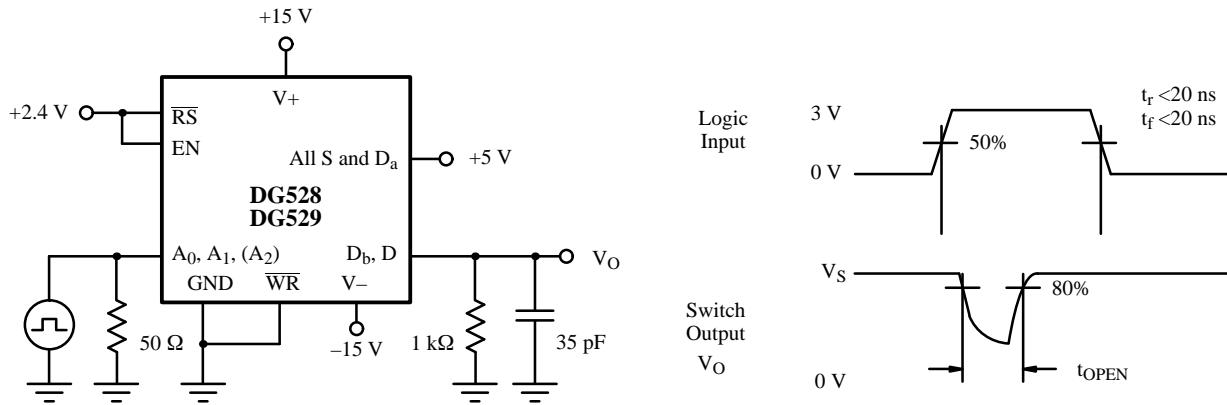

Figure 4. Break-Before-Make

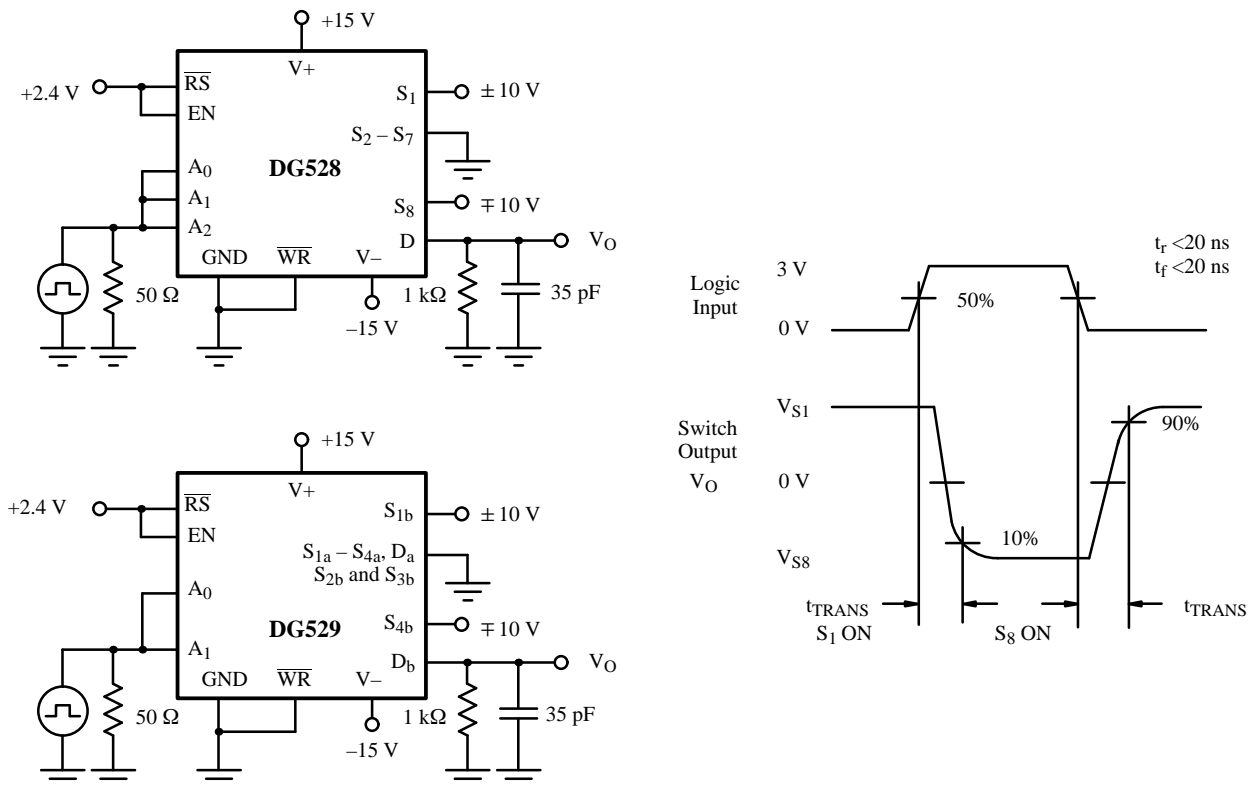
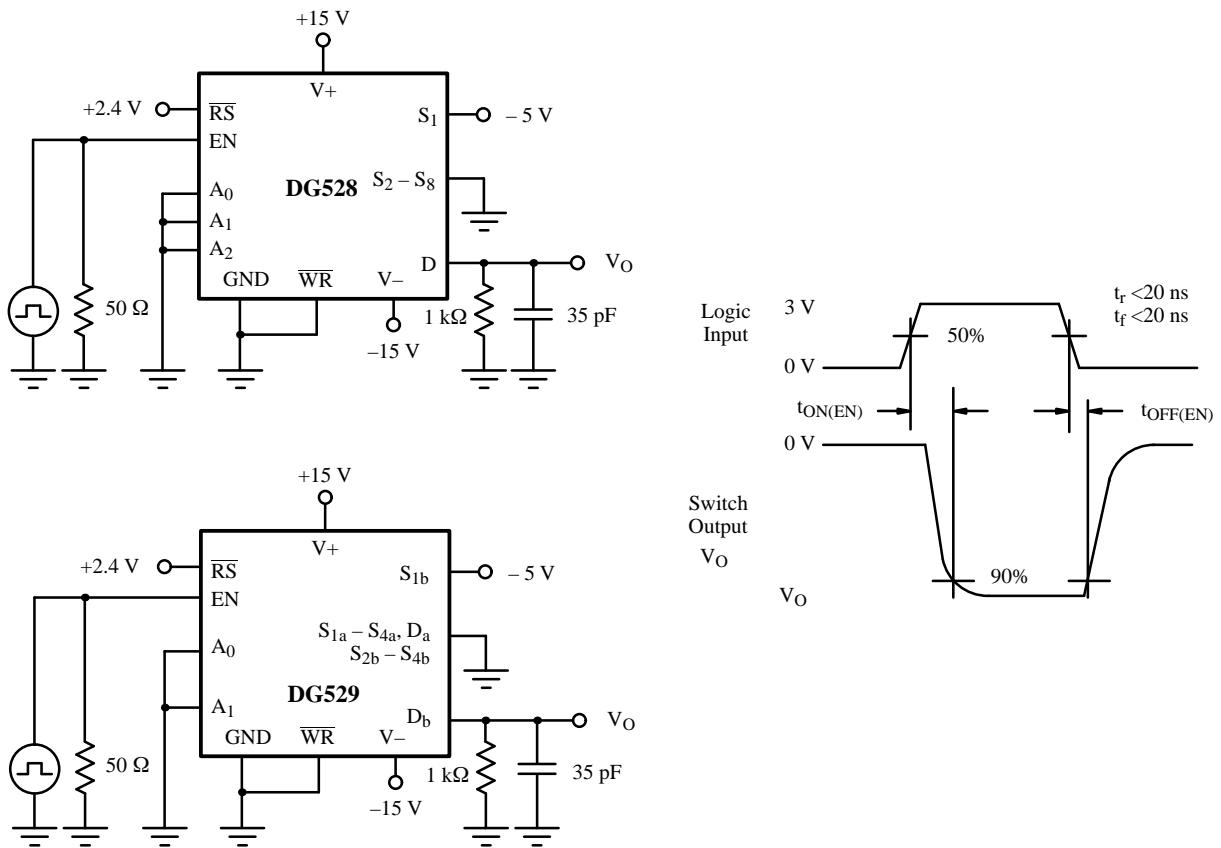
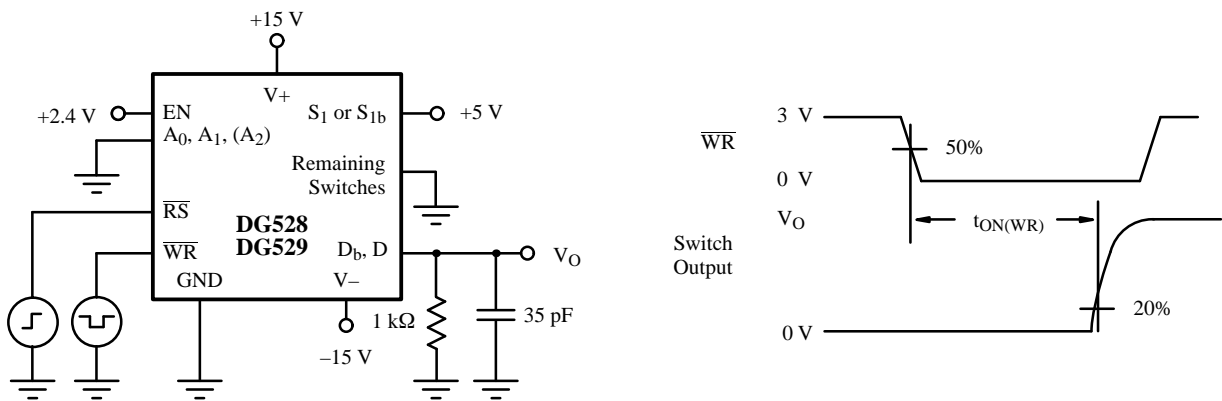

Figure 5. Transition Time

**Test Circuits (Cont'd)**

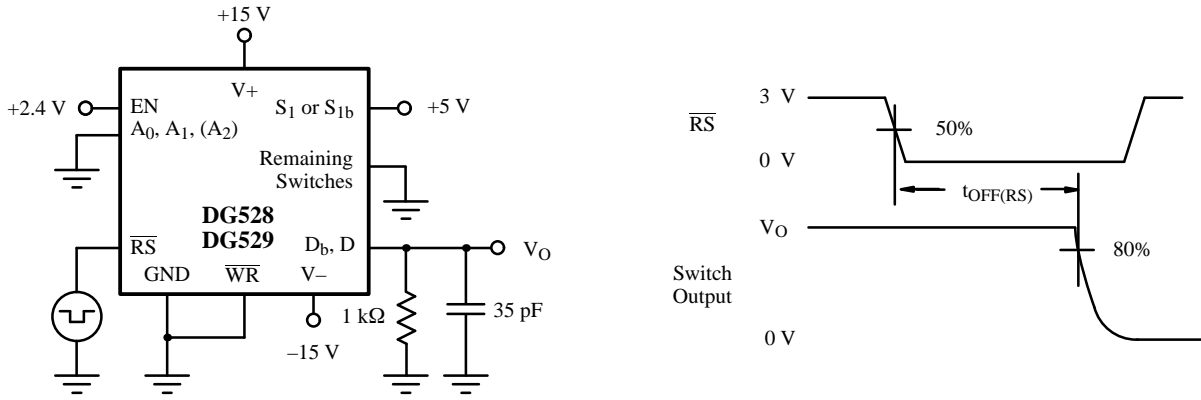

**Figure 6.** Enable  $t_{ON}/t_{OFF}$  Time

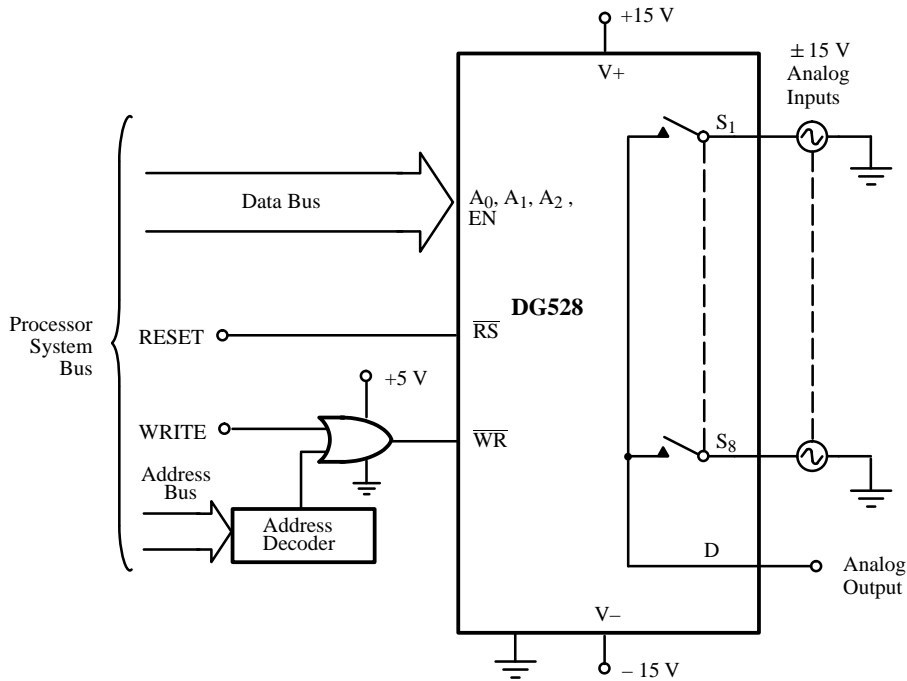

**Figure 7.** Write Turn-On Time  $t_{ON(WR)}$

## Test Circuits (Cont'd)



**Figure 8.** Reset Turn-Off Time  $t_{OFF(RS)}$



**Figure 9.** Bus Interface



## Application Hints<sup>a</sup>

V+ Positive Supply Voltage (V)	V- Negative Supply Voltage (V)	V <sub>IN</sub> Logic Input Voltage V <sub>INH(min)</sub> /V <sub>INL(max)</sub> (V)	V <sub>S</sub> or V <sub>D</sub> Analog Voltage Range (V)
20	-20	2.4/0.8	± 20
15 <sup>b</sup>	-15	2.4/0.8	± 15
8 <sup>c</sup>	-8 (min)	2.4/0.8	± 8

Notes:

- Application Hints are for DESIGN AID ONLY, not guaranteed and not subject to production testing.
- Electrical Parameter Chart based on V<sub>+</sub> = 15 V, V<sub>L</sub> = 5 V, V<sub>R</sub> = GND.
- Operation below ± 8 V is not recommended.

## Bus Interfacing

The DG528/DG529 minimize the amount of interface hardware between a microprocessor system bus and the analog system being controlled or measured. The internal TTL compatible latches give these multiplexers write-only memory, that is, they can be programmed to stay in a particular switch state (e.g., switch 1 on) until the microprocessor determines it is necessary to turn different switches on or turn all switches off (see Figure 9).

The input latches become transparent when  $\overline{WR}$  is held low; therefore, these multiplexers operate by direct command of the coded switch state on A<sub>2</sub>, A<sub>1</sub>, A<sub>0</sub>. In this mode the DG528 is identical to the popular DG508A. The same is true of the DG529 versus the popular DG509A.

During system power-up,  $\overline{RS}$  would be low, maintaining all eight switches in the off state. After  $\overline{RS}$  returned high the DG528 maintains all switches in the off state. When the system program performs a write operation to the address assigned to the DG528, the address decoder provides a  $\overline{CS}$  active low signal which is gated with the WRITE ( $\overline{WR}$ ) control signal. At this time the data on the DATA BUS (that will determine which switch to close) is stabilizing. When the  $\overline{WR}$  signal returns to the high state, (positive edge) the input latches of the DG528 save the data from the DATA BUS. The coded information in the A<sub>0</sub>, A<sub>1</sub>, A<sub>2</sub> and EN latches is decoded and the appropriate switch is turned on.

The EN latch allows all switches to be turned off under program control. This becomes useful when two or more DG528s are cascaded to build 16-line and larger multiplexers.